

BERT FRANK

REVOLVE WALL LIGHT

MAINTENANCE

- Lacquered brass and diffuser should be wiped with a soft duster.
- Coloured parts can be wiped with a damp cloth (unplug from mains first).

TECHNICAL

- 3 x G9 LED bulbs

www.bertfrank.co.uk
+44 (0)207 164 6482

INSTALLATION

- 1** - Feed electrical cable from wall through the wiring exit hole in mounting plate.
- Screw plate to wall.

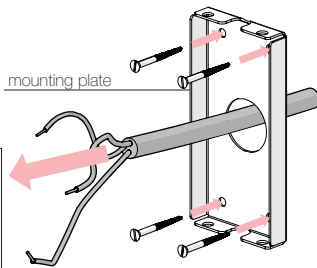

!!

Use appropriate screws and plugs for the material you are fixing it to.

!!

- 2** - Make electrical connection.
- Connector block not supplied but ensure a suitable type is used.
- Ensure to connect earth wire to earth in mains feed.

!!

Ensure this is done by a qualified electrician.

!!

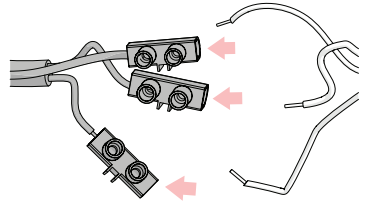

- 3** - Screw the wall cover to mounting plate with 4 x screws at the top and bottom of cover.

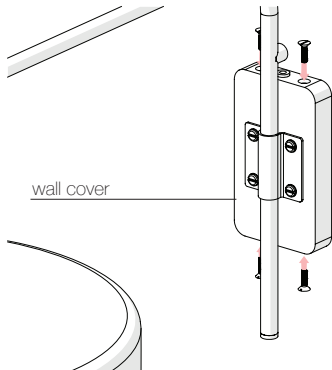

- 4** - To adjust the shade to the desired position, move it from left to right. The head can also be tilted.

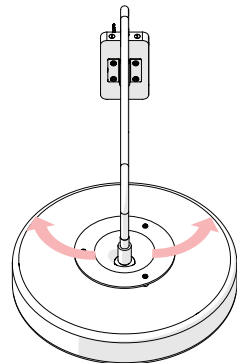

BULB REPLACEMENT

1

- Turn off the light at the mains.
- Unscrew the bottom finial.

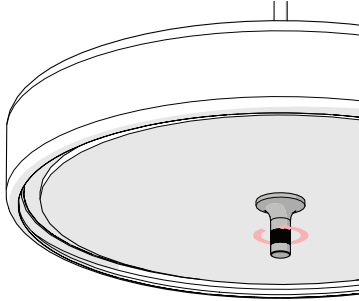

2

- Remove the bottom finial and diffuser.

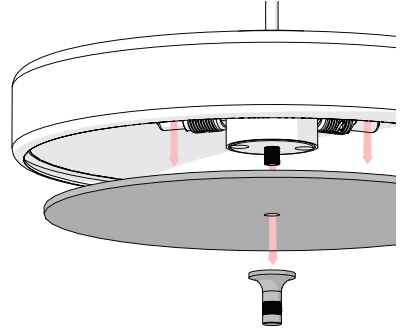

3

- Replace bulbs by pushing them into lamp holder.
- Once bulbs are installed replace diffuser and bottom finial.

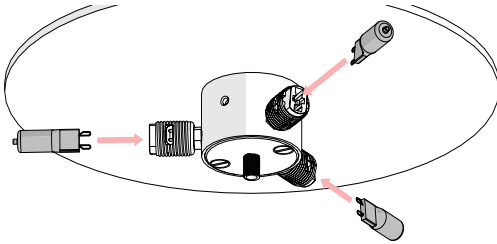

4

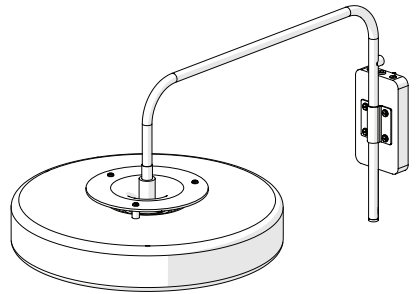

This product is only suitable for connection to the native power supply to which the unit was specifically manufactured. It is for indoor use only, and not suitable for a bathroom location.

If the Class II, double insulated symbol is on the lamp, it does not require an Earth, and Live or Neutral must not be connected to Earth. If there is no such symbol, then the lamp must be Earthed.

Under no circumstances must this table lamp be covered with any material as this could pose a safety hazard. It must be used on a stable, flat surface.

Never fit bulbs of a higher wattage than those specified on the label, as these may cause overheating and damage the fitting.

If the mains cable becomes damaged it must only be replaced by a technically competent, qualified person.

Allow 10 minutes to cool before replacing, adjusting or cleaning. Clean with a dry cloth only. Do not use liquid or abrasive cleaners on this product.

If you are in any doubt about your competence please consult a qualified electrician. If any modification is made it will invalidate the warranty and may render the product unsafe.